

Series 160P Differential Pressure Switch

Mid-range, adjustable differential pressure switch. Efficient Nega-Rate® Belleville disc spring sensing mechanism for stable set points during system pressure changes. Hermetically sealed, explosion-proof electrical assembly well suited for hazardous or explosive environments.

Operating Pressure Data

Adjustable Range Number	Adjustable Set Point Range		Deadband (approximate)	Maximum Recommended System Pressure	Proof Pressure
	Increasing	Decreasing			
2	1.1 to 15	.75 to 14.65	.35	300	500 Hi/Low 200 Low/Hi
4	1.5 to 18	.3 to 16.8	1.2	500	1000 Hi/Low 400 Low/Hi
6	5 to 60	2 to 57	3	500	1000 Hi/Low 400 Low/Hi
7	55 to 110	49 to 104	6	500	1000 Hi/Low 400 Low/Hi

All values given in psid.

Standard Specifications

Electrical

Snap action electrical switch assemblies, Part Numbers 057-0770 & 057-0772 (Form C) and 057-0771 & 057-0773 (Form CC), are listed by Underwriters' Laboratories, Inc., FM Approvals, CSA International and NCC (INMETRO). See the miscellaneous option N for additional listings.

Electrical Connection

1/2 NPT male conduit connection with PVC insulated 18 AWG, 18" long leads

Pressure Connection

1/4 NPT Female

Temperature Range*

Ambient: -40°F to +180°F
(-40°C to +82°C)

Media: -40°F to +250°F
(-40°C to +121°C)

*Temperature limits change with O-Ring selection. See Electrical Assembly specification sheet for Temperature Class Ratings.

Adjustment

Concealed wrench flat adjustment with range scale

Shipping Weight

Approximately 3.5 pounds



Order Miscellaneous Option "D"



Explosion Proof Hermetically Sealed (NEMA 4X, 7, 9 and 13)

Ordering Sequence — Select desired option for each category

OPTIONS

Wetted Material

- 1 Aluminum port and body, Teflon coated polyimide diaphragm, Buna-N O-Rings and stainless steel
- 4 Stainless steel, Teflon coated polyimide diaphragm and Buna-N O-Rings

Adjustable Range

- 2 .75 psid dec. to 15 psid inc. (0.1 bar dec. to 1.0 bar inc.)
- 4 .3 psid dec. to 18 psid inc. (0.0 bar dec. to 1.2 bar inc.)
- 6 2 psid dec. to 60 psid inc. (0.1 bar dec. to 4.1 bar inc.)
- 7 49 psid dec. to 110 psid inc. (3.4 bar dec. to 7.6 bar inc.)

Electrical Form

- C 11 amp, 1/4 hp at 125 or 250 VAC; 5 amp resistive, 3 amp inductive at 28 VDC; .5 amp resistive at 125 VDC
- CC 11 amp, 1/4 hp at 125 or 250 VAC; 5 amp resistive, 3 amp inductive at 28 VDC; .5 amp resistive at 125 VDC

Enclosure

- 6 Includes an explosion proof, hermetically-sealed electrical assembly. EX d IIC. Division 1 and 2, Class I, Groups A, B, C, and D; Class II, Groups E, F, and G. NEMA 4X, 7, and 9; IP66. Leads are factory sealed and Pressure Switches are Dual Seal Certified.

Miscellaneous

- A Epoxy paint exterior — extra protection for severe environments
- B Viton O-Ring
- C EPR O-Ring
- D SIL approval and marking, per IEC61508 (includes FMEA report)
- I 3/4 NPT conduit box with terminal strip (Groups C & D only, not available with N option)
- M Gold electrical contacts for extremely low current applications (1 Amp at 125 VAC; 1 Amp Res, 0.5 Amp Ind. at 28 VDC)
- N ATEX and IECEx with CE Mark
- R 72" Electrical free leads
- S Stainless steel diaphragm — No low over high capability (Ranges 2 & 4, Wetted Material 4 only)
- U M20 x 1.5 Electrical Conduit Adapter

Special (Consult representative or factory)

- Non-catalog adjustable range and/or set point, deadband and proof pressure
- Media temperature capability from -65°F to +350°F
- Chemical seals installed
- Optional orientation of Low Pressure Port

Ordering Procedure

- When factory presetting is desired, stipulate set point, increasing or decreasing and system pressure
- Insert available option number or letter designation as required

Example

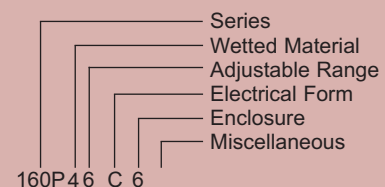

Series 160P Differential Pressure Switch

Field Adjustable
.3 to 110 psid

Envelope Dimensions

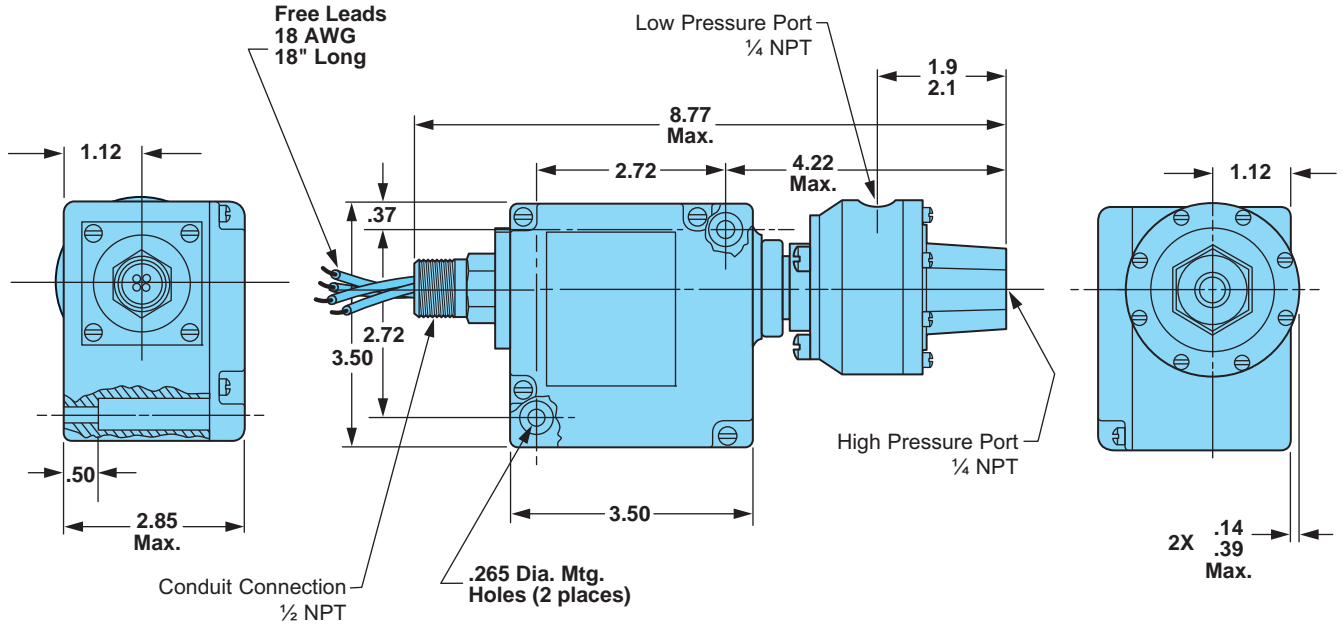

Electrical Form

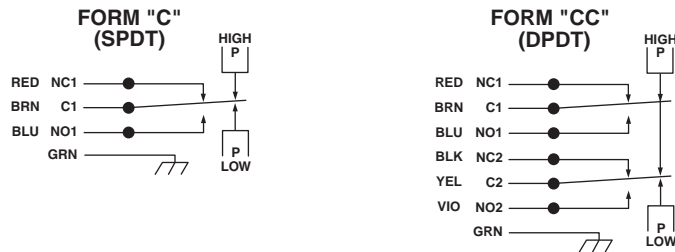

Basic Principles of Design

